



AEROMOTIVE
Part # 17143 & 17144
96-98 1/2 4.6L DOHC Return Style Fuel System Kit
INSTALLATION INSTRUCTIONS

CAUTION:

Installation of this product requires detailed knowledge of automotive systems and repair procedures. We recommend that this installation be carried out by a qualified automotive technician.

Installation of this product requires handling of gasoline. Ensure you are working in a well ventilated area with an approved fire extinguisher nearby. Extinguish all open flames, prohibit smoking and eliminate all sources of ignition in the area of the vehicle before proceeding with the installation.

When installing this product, wear eye goggles and other safety apparel as needed to protect yourself from debris and sprayed gasoline.

WARNING!

The fuel system is under pressure. Do not open the fuel system until the pressure has been relieved. Refer to the appropriate vehicle service manual for the procedure and precautions for relieving the fuel system pressure.

Aeromotive system components are not legal for sale or use on emission controlled motor vehicles.

This kit assumes you have a sumped fuel tank or fuel cell with provisions for a gravity feed AN-10 supply line and AN-06 return line.

Maximum continuous operating pressure should not exceed 70 psi.

This kit contains the following parts:

- | | |
|--|---|
| 1 ea fuel pump wiring kit | 1 ea p/n 13101 Fuel Pressure Regulator |
| 1 ea 3ft length of 10 ga. Black wire | 1 ea p/n 14104 Ford 4.6L DOHC Fuel Rails |
| 1 ea 25ft length of 10 ga. Red wire | 1 ea Y-block Assembly |
| 1 ea 30 amp circuit breaker | 2 ea p/n 15607 AN-08 cutoff union |
| 1 ea 30 amp automotive relay | 2 ea AN-08 o-ring |
| 2 ea blue female blade connector | 1 ea p/n 15610 AN-10 cutoff to AN-08 union |
| 2 ea yellow female blade connector | 1 ea AN-10 o-ring |
| 5 ea yellow #10 stud ring connector | 4 ea 1/4" flat washers |
| 1 ea yellow 3/8" stud ring connector | 4 ea 1/4-20 nyloc nuts |
| 6 ea tie-wraps | 4 ea 1/4-20 x 1" carriage bolts |
| 4 ft AN-10 stainless steel braided line | 12 ea tie-wraps |
| 16 ft AN-06 stainless steel braided line | 1 ea AN-06 o-ring |
| 26 ft AN-08 stainless steel braided line | 4 ea AN-08 o-ring |
| 2 ea AN-10 90-degree hose end | 8 ea AN-10 o-ring (17143 kit only) |
| 2 ea AN-08 straight hose end | 7 ea AN-10 o-ring (17144 kit only) |
| 6 ea AN-08 90-degree hose end | 1 ea AN-12 o-ring (17144 kit only) |
| 2 ea AN-08 Male 90-degree hose end | 1 ea p/n 15606 AN-06 cutoff union |
| 1 ea AN-06 straight hose end | 2 ea p/n 15607 AN-08 cutoff union |
| 1 ea AN-06 90-degree hose end | 3 ea p/n 15608 AN-10 cutoff union (17143 kit only) |
| 1 ea p/n 11101 Pump (17143 Kit only) | 2 ea p/n 15608 AN-10 cutoff union (17144 kit only) |
| 1 ea p/n 11104 Pump (17144 Kit only) | 3 ea p/n 15610 AN-10 cutoff to AN-08 union |
| 1 ea p/n 12304 Filter 100 Micron SS | 1 ea p/n 15613 AN-12 cutoff to AN-10 union (17144 kit only) |
| 1 ea p/n 12301 Filter 10 Micron Paper | |

Warning – The included Aeromotive fuel pump is not compatible with alcohol based fuels or fuel additives!

The following steps are typical of most installations:

Section 1 - Fuel Pump Installation

Section 2 – Fuel Rail Installation

Section 3 – Fuel Regulator Installation and Fuel Line Plumbing

Section 4 – Fuel Line Hose End Installation

Section 5 – Electrical Installation

Section 6 – Final Checks and System Start-up

Fuel Pump Template

Typical hose end to fitting connection:

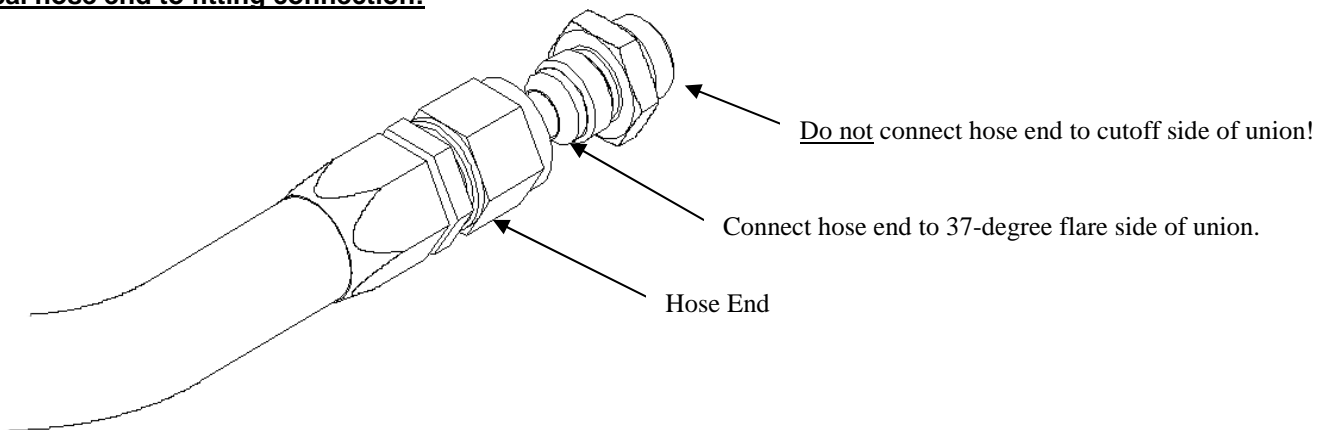

Typical o-ring sealed port connection:

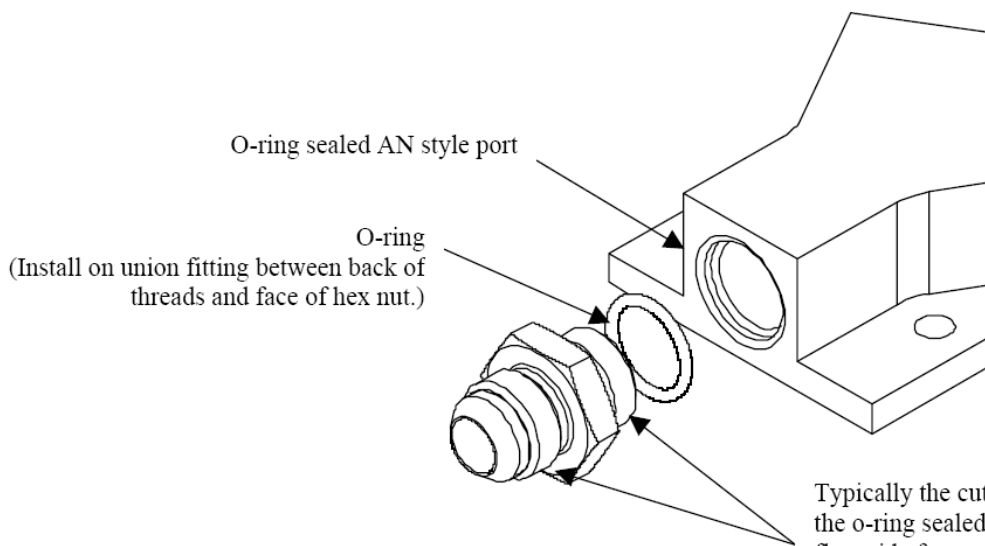

Typically the cutoff side of the union is used as the o-ring sealed side, leaving the 37-degree flare side for your hose end connection. In some cases both sides of the union utilize an o-ring seal.

For example, in some systems an ORB to Flare fitting is used to connect the fuel pump and filter together, in which case you always install the ORB side into the fuel pump and the flare side with O-ring added into the filter.

Section 1 - Fuel Pump Installation:

- 1-1. Once the engine has been allowed to cool, disconnect the negative battery cable and relieve the fuel system pressure.
- 1-2. Raise the vehicle and support it with jack stands.
- 1-3. Find a suitable mounting location for your Aeromotive fuel pump / filter assembly, the following steps outline mounting the assembly on the OE plastic fuel tank shield. If you choose not to mount the pump / filter assembly to this shield adjust the installation procedure as necessary.
- 1-4. Referring to the appropriate vehicle service manual for instructions, drain, disconnect any electrical and fuel component connections and remove the OEM fuel tank. The removal of the vehicles exhaust system may be necessary for fuel tank removal.
- 1-5. Once the OEM fuel tank has been removed, remove the plastic fuel tank shield from the bottom of the tank.
- 1-6. If you have kit 17143:

In the kit find two AN-10 cutoff union fittings and four of the AN-10 o-rings. Install each of the four o-rings on each end of the two AN-10 cutoff union fittings.
- If you have kit 17144:

In the kit find one AN-10 cutoff union fitting, one AN-12 cutoff to AN-10 union fitting, the AN-12 o-ring and three of the AN-10 o-rings. Install each of the four o-rings on the appropriate ends of the two fittings.
- 1-7. Install each of the two AN-10 cutoff fittings into each end of the provided Aeromotive fuel pump.
- 1-8. Noting the appropriate flow directions, install the provided fuel filter, Aeromotive p/n 12301, on the fuel pump outlet and the other fuel filter, Aeromotive p/n 12304, on the fuel pump inlet.

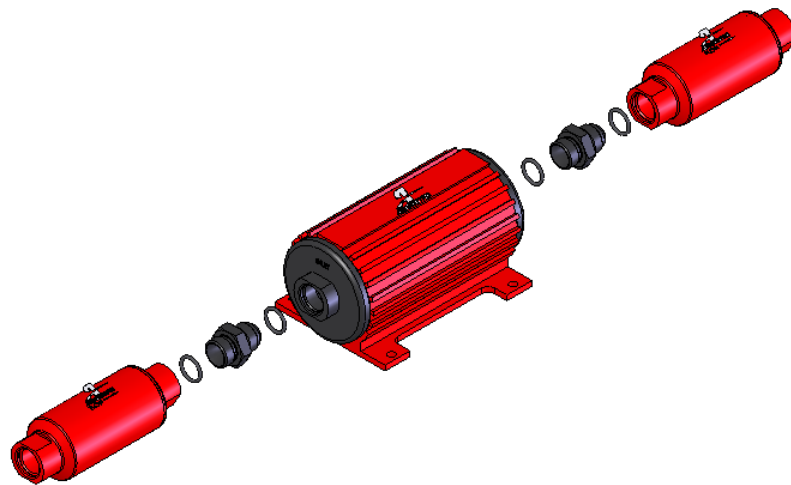

- 1-9. Install one of the supplied AN-10 o-rings on the cutoff side of the AN-10 cutoff union fitting, if not already installed, and install on the inlet side of the pump / filter assembly.
- 1-10. Install one of the supplied AN-10 o-rings on the AN-10 cutoff side of the AN-10 cutoff to AN-08 reducer union fitting, if not already installed, and install on the outlet side of the pump / filter assembly.

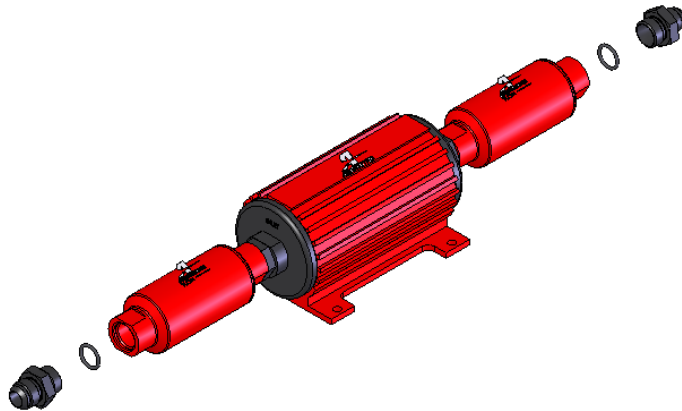
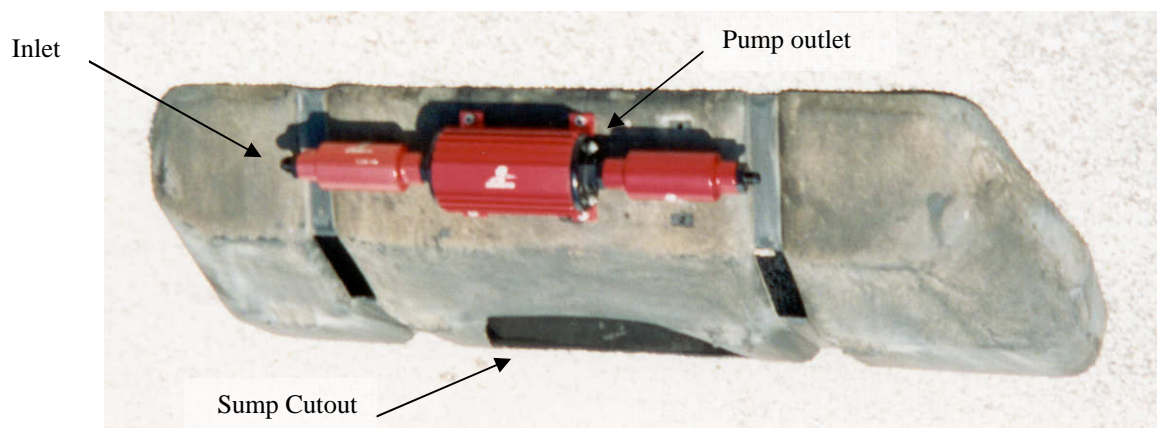

Figure 1-2

- 1-11. Position the fuel pump / filter assembly from above on the opposite end of the plastic fuel tank shield as the sump cutout. Center the pump / filter assembly in all directions on the flat. Using the fuel pump as a guide, mark the four pump mounting holes. Insure there are no obstructions behind the plastic fuel tank shield and drill four 1/4" mounting holes.
- 1-12. The fuel pump should be installed such that when the plastic fuel tank shield is installed the fuel pump outlet is on the driver side of the vehicle. Secure the fuel pump to the plastic fuel tank shield by installing each of the four 1/4" carriage bolts from the inside of the fuel tank shield, through the fuel tank shield and through the fuel pump mounting holes. Install each of the four provided flat washers and nuts on the bolts and tighten. The plastic fuel tank shield now should look similar to the one shown below.



- 1-13. Inspect the inside of the plastic fuel tank shield for any sharp edges that could puncture the fuel tank. If any sharp edges are found, correct before proceeding.
- 1-14. Position the plastic fuel tank shield on the Aeromotive fuel tank.
- 1-15. Using the two supplied 90-degree AN-10 hose ends as a guide, measure the length of AN-10 steel braided line needed to connect the fuel tank sump outlet to the fuel pump / filter assembly inlet.
- 1-16. Cut and assemble the steel braided hose and hose ends as shown in Section 4.

1-17. Using the above steel braided hose assembly, connect one end to the outlet of the fuel tank sump and the other end to the fuel pump / filter assembly inlet and tighten.

Note: It is recommended that a fuel shut off valve be installed between the fuel tank outlet and the fuel pump / filter assembly inlet, these valves are available from most popular racing fitting manufactures; Aeroquip, Earl's, Goodridge, Russell, etc.



1-18. Using any type of household tape, secure the plastic fuel tank shield to the Aeromotive fuel tank along each of the fuel tank strap indentations.

1-19. Carefully flip the fuel tank / plastic fuel tank shield assembly over.

1-20. Position the fuel tank under the vehicle. Apply a light weight oil to the filler neck grommet to ease installation.

1-21. In vehicles engine compartment, locate a suitable mounting location for the supplied fuel pressure regulator

1-22. Starting from the decided regulator mounting location in the engine compartment, plan a route to run an AN-06 return line back to your fuel tank / fuel cell AN-06 return port and measure the required length. Cut the return line to the determined length and install one AN-06 90-degree hose end and one AN-06 straight hose end, as detailed in Section 4.

Note: Be sure to route all fuel lines clear of any moving suspension or drivetrain components and any exhaust components! Protect fuel lines from abrasion and road obstructions or debris.

1-23. Thread the 90-degree hose end side of the AN-06 return line onto the AN-06 return port fitting located on your sumped fuel tank / fuel cell, and tighten.

1-24. As your fuel tank is lifted into position reattach the vent line to the top of the fuel tank and work the filler neck in to the grommet on the side of the fuel tank. Once your fuel tank is in position, align tank straps, ensure that there are not any hoses or wiring pinched and tighten the strap bolts.

1-25. Make any line or electrical adjustments necessary to clear the vehicles exhaust, suspension, and drivetrain components.

Section 2 – Fuel Rail Installation

- 2-1. Check for any dirt or debris around the fuel injectors. If any is evident, wash it off with some solvent parts cleaner or wipe it off with a clean shop towel.
- 2-2. Disconnect the electrical connector at each injector, making note of the location of each.
- 2-3. Disconnect both the supply and return (If applicable) fuel lines from the OEM fuel rails. These lines are attached by a special quick disconnect fitting which requires a special tool for removal. Place clean shop towels around the open fuel lines to catch any gasoline that may drip out and to prevent any dirt from entering the fuel lines.
- 2-4. Remove the air intake tube.
- 2-5. Label and disconnect any electrical wiring, vacuum lines and throttle body components that will interfere with the fuel rail removal and installation.
- 2-6. Remove the 4 mounting bolts that attach the fuel rail to the intake manifold.
- 2-7. Place clean shop towels around the injectors to catch any gasoline that may be spilled during their removal. Remove the injectors from the manifold by gently pulling upward on the fuel rail / injector assembly. Keep all injectors connected to the fuel rails. If an injector does pull out of the fuel rail, it may spill a large amount of fuel.
- 2-8. Carefully remove the fuel injectors from the fuel rail.
- 2-9. Remove the old o-rings from the fuel injectors, inspect the injectors for any dirt or debris and clean if needed. It is suggested that the old o-rings be replaced, contact your local auto parts store for replacement o-rings.
- 2-10. Coat the new fuel injector o-rings with a light oil or petroleum jelly to ease installation.
- 2-11. Carefully install the new fuel injector o-rings on the injectors.
- 2-12. Place a thin coat of light oil or petroleum jelly in the fuel rail fuel injector bores and in the lower intake manifold injector bores to help prevent cutting the o-rings during installation.
- 2-13. Carefully place each of the fuel injectors in the corresponding fuel injector bore of the Aeromotive fuel rails. Position the electrical connector on each fuel injector to the opposite side of the fuel rail as the mounting bracket.
- 2-14. Place each of the fuel rail / injector assemblies onto the lower intake manifold, ease the fuel injectors into the injector bores in the lower intake being careful that the injector does not dislodge itself from the fuel rail.
- 2-15. Reinstall the fuel rail mounting bolts and tighten.
- 2-16. Reinstall any electrical wiring, vacuum lines, and throttle body components that were removed for the original fuel rail removal.

Section 3 – Fuel Regulator Installation and Fuel Line Plumbing

- 3-1. In the vehicle's engine compartment, mount the supplied fuel pressure regulator in the location established in step 1-26. Using the supplied mounting bracket as a template, mark the bracket mounting holes and drill to accept a #10 screw.
- 3-2. With the bracket attached to the regulator, mount the bracket and regulator to the vehicle using two #10 screws, nuts and lock washers.
- 3-3. Install two of the supplied AN-10 o-rings on the cutoff side of two AN-10 cutoff to AN-08 reducer union fittings, if not already installed, and install in each of the AN-10 ports located on the sides of the supplied fuel pressure regulator.

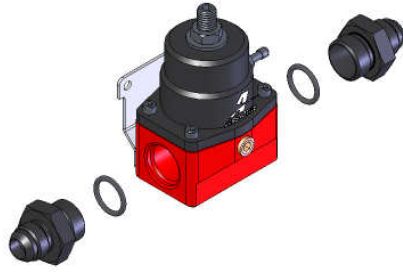

- 3-4. Install one of the supplied AN-06 o-rings on the cutoff side of the AN-06 cutoff union fitting, if not already installed, and install in the AN-06 port located on the bottom of the supplied fuel pressure regulator.

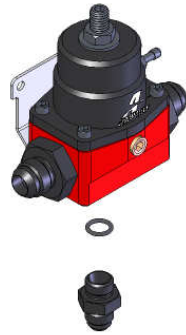

- 3-5. Install two of the supplied AN-08 o-rings on the cutoff side of two AN-08 cutoff union fittings, if not already installed.
- 3-6. Install these two AN-08 fittings on the rear side of each fuel rail.

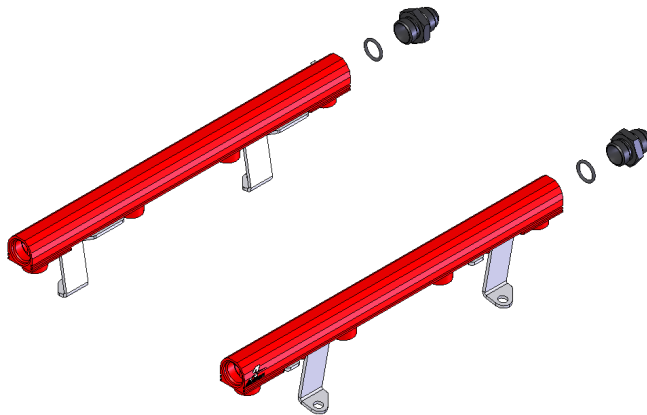

3-7. Install two of the supplied AN-08 o-rings on the two supplied AN-08 90-degree Male Hose ends.



3-8. Using the above two AN-08 90-degree male hose ends and two standard AN-08 90-degree hose ends at the regulator, plan a route to run an AN-08 supply line from the front of each fuel rail to each side of the regulator. Cut the two supply lines to the determined length and install the AN-08 hose ends, as detailed in Section 4.

Note: Be sure to route all fuel lines clear of any moving suspension or drivetrain components and any exhaust components! Protect fuel lines from abrasion and road obstructions or debris.

3-9. Using the above steel braided hose assemblies, connect one end to the side of the fuel pressure regulator and the other end to the fuel rails and tighten.

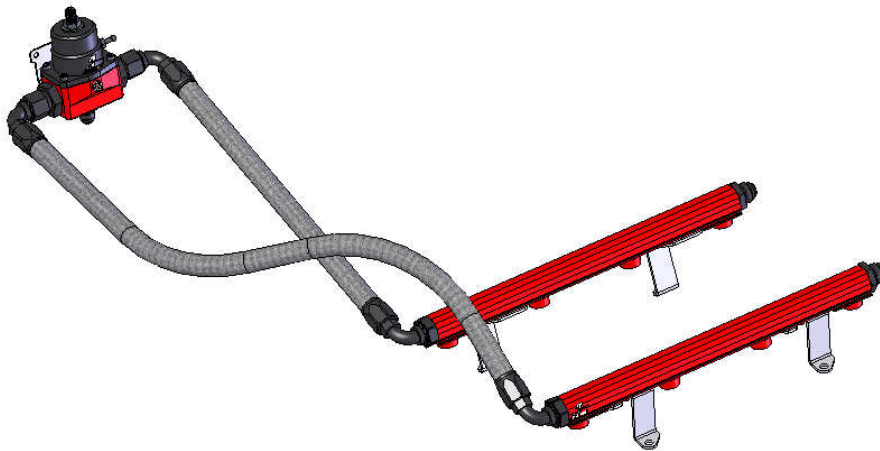

3-10. In the vehicle's engine compartment, find a suitable mounting location near the fuel rails for the supplied Y-Block, using the Y-block as a template, mark the mounting holes and drill to accept a #10 screw.

3-11. Attach the Y-block to the vehicle using two #10 screws, nuts and lock washers.

3-12. Install two of the supplied AN-08 o-rings on the cutoff side of two AN-08 cutoff union fittings, if not already installed, and install in each of the AN-08 ports located on the supplied Y-Block. Install one of the supplied AN-10 o-rings on the cutoff side of the AN-10 to AN-08 reducer union fitting, if not already installed, and install in the AN-10 port located on the supplied Y-Block.



3-13. Starting from the fuel rails, plan a route to run an AN-08 supply line from each fuel rail to each side of the Y-block. Cut the two supply lines to the determined length and install the AN-08 hose ends, as detailed in Section 4.

Note: Be sure to route all fuel lines clear of any moving suspension or drivetrain components and any exhaust components! Protect fuel lines from abrasion and road obstructions or debris.

3-14. Using the above steel braided hose assemblies, connect one end to the Y-block and the other end to the fuel rails, as shown in figure 3-1, and tighten.

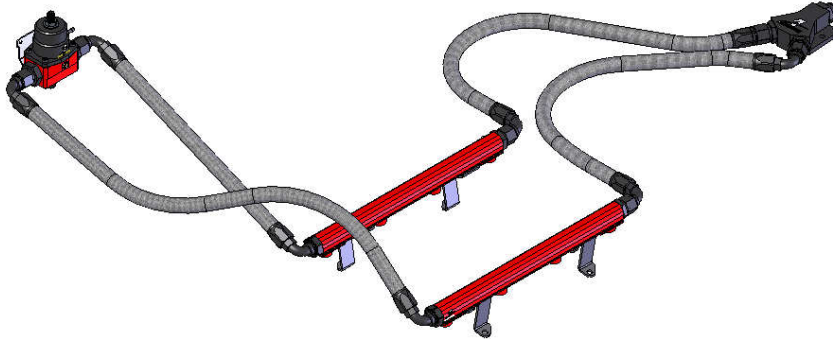

3-15. Starting from the outlet of the fuel pump / filter assembly, plan a route to run an AN-08 supply line from fuel pump / filter assembly to the Y-block, this line should be run along the same route you planned to run the return line in step 1.27. Cut the supply line to the determined length and install the AN-08 hose ends, as detailed in Section 4.

Note: Be sure to route all fuel lines clear of any moving suspension or drivetrain components and any exhaust components! Protect fuel lines from abrasion and road obstructions or debris.

3-16. Using the above steel braided hose assembly, connect one end to the outlet of the fuel pump / filter assembly. Keeping both the supply line and return line from the Aeromotive fuel tank together, secure both lines to the vehicle along the predetermined route using the supplied tie-wraps. Once both lines are to their destination, the supply line to the Y-block and the return line to the bottom of the regulator and tighten.

Note: Be sure to route all fuel lines clear of any moving suspension or drivetrain components and any exhaust components! Protect fuel lines from abrasion and road obstructions or debris.



3-17. Once the regulator is installed, attach a suitable fuel pressure gauge (not supplied) to the 1/8 NPT port on the fuel pressure regulator.

Section 4 - Fuel Line Hose End Installation:

CAUTION:

When assembling this product, wear eye goggles and other safety apparel as needed to protect yourself from debris and sharp edges.

4-1. Wrap hose with masking tape at desired cutoff length. Cut hose through masking tape squarely to desired length using a cut-off machine or a fine tooth hacksaw. Remove the masking tape.

4-2. Unthread the hose socket from the rest of the hose end fitting.



4-3. Insert hose in the socket with a twisting and pushing motion until the hose is fully seated in the socket.



4-4. Using a grease pencil, marker or tape, mark the location of the hose in relation to the hose socket that you just installed.

4-5. Using a light oil, lubricate the inside of the hose and hose end mating parts.

4-6. Carefully thread the hose end onto the hose socket, making sure that the hose does not push out of socket, by observing the mark you placed on the hose in step 3-4.



4-7. Using a properly sized wrench, complete threading the two components together (The maximum allowable gap between the two fitting components is .030 inches).



4-8. Inspect the hose for push out by comparing the mark you made on the hose in step D to the hose end socket location.

4-9. Clean all debris from exterior and interior of hose.

4-10. All lines should be tested to twice their operation pressure prior to use.

Section 5 - Electrical Installation:

5-1. Find a suitable place to mount the supplied relay, the relay is typically mounted by the OEM fuel pump wiring connector (***Never mount the relay inside of the fuel tank or next to fuel tank vents!***). Insure the relay and any associated parts are clear of the exhaust, any moving suspension or drivetrain components and any possible road obstructions or debris.

5-2. Attach the OEM fuel pump wires (These typically are the red and black wires from the OEM wiring harness going to the fuel tank) to relay terminals 85 and 86 using two of the supplied blue female blade connectors (See Figure 5-1 Below).

Note: Be sure to route all electrical wires clear of any moving suspension or drivetrain components, and any exhaust components! Protect wires from abrasion and road obstructions or debris.

5-3. Find a suitable location for mounting the supplied circuit breaker. For optimal circuit protection, the circuit breaker needs to be mounted as close to the battery as possible.

5-4. Connect terminal number 30 on the relay to the circuit breaker by using the supplied red 10 ga. wire, one of the yellow female blade connectors on the relay end of the wire and one of the yellow #10 ring connectors on the circuit breaker side of the wire.

Note: Be sure to route all electrical wires clear of any moving suspension or drivetrain components and any exhaust components! Protect wires from abrasion and road obstructions or debris.

5-5. Connect terminal number 87 on the relay to the positive terminal on the fuel pump. This is accomplished by using the supplied red 10 ga wire, one of the yellow female blade connectors on the relay side of the wire and one of the yellow #10 ring connectors (or appropriate connector for the installation) on the fuel pump side of the wire.

5-6. Connect the negative terminal on the fuel pump to a clean chassis ground using the supplied black 10 ga wire and two yellow #10 ring connectors.

5-7. Connect 12VDC to the circuit breaker using the supplied red wire and one of the yellow #10 ring connectors and the supplied yellow 3/8" ring connector.

5-8. Ensure that electrical components and wires are connected properly (See Figure 5-1) and are clear of any moving suspension or drivetrain components and any exhaust components! Protect wires from abrasion and road obstructions or debris.

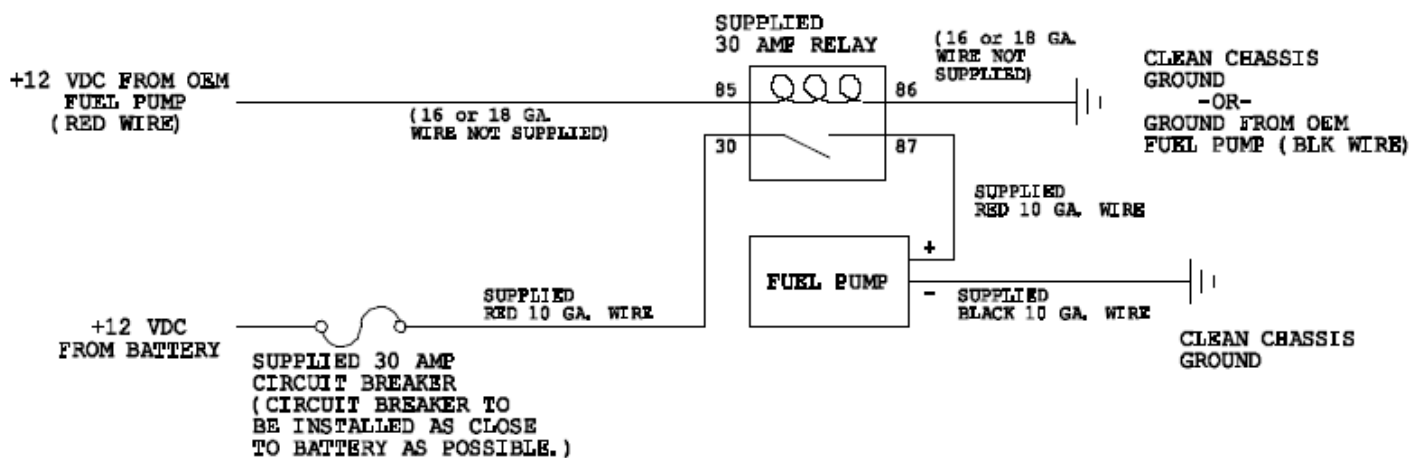

Figure 5-1

Section 6 – Final Checks and System Start-up

6-1. **Ensure that any spilled gasoline and any gasoline soaked shop towels are cleaned up and removed from the vicinity of the vehicle!**

6-2. Carefully lower the car onto the ground.

6-3. Fill the fuel tank with gasoline and check for any leaks in the system, if any leaks are found repair immediately.

CAUTION: While performing the following steps, if any fuel leaks are detected, immediately turn the ignition of OFF, remove any spilled fuel and repair the leak(s) before proceeding!

6-4. Reconnect the battery and turn the ignition to the ON position **WITHOUT** starting the car. After several seconds, check the fuel pressure. If there is no fuel pressure, turn the ignition key to the OFF position, wait one minute, return the ignition to the ON position, and recheck the fuel pressure. Repeat this ignition OFF and ON procedure until the fuel pressure gauge registers fuel pressure.

6-5. With the fuel pressure gauge registering fuel system pressure, check for fuel leaks throughout the entire fuel system! If any fuel leaks are found, turn the ignition key to the OFF position, remove any spilled fuel and repair the leak before proceeding!

6-6. Once the fuel pressure gauge registers fuel system pressure and there are no fuel leaks, start the engine and adjust the regulator to the desired fuel pressure. Turning the adjustment screw clockwise will increase fuel pressure. OEM regulators are typically set at approximately 43 psi, without the vacuum line attached. The fuel pressure adjustment range for this regulator is 35-80 psi.

6-7. Once the desired fuel pressure is achieved, tighten the regulator adjustment jam nut and attach the vacuum line.

6-8. Test drive the car to insure proper operation and re-check the fuel system for leaks. If any leaks are found, immediately discontinue use of the vehicle and repair the leak(s)!

AEROMOTIVE, INC. LIMITED WARRANTY

This Aeromotive Product, with proof of purchase dated on or after January 1, 2003, is warranted to be free from defects in materials and workmanship for a period of one year from the original date of purchase. No warranty claim will be valid without authentic, dated proof of purchase.

This warranty is to the original retail purchaser and none other and is available directly from Aeromotive and not through any point of distribution or purchase.

If a defect is suspected, the retail purchaser must contact Aeromotive directly to discuss the problem, possible solutions and obtain a Return Goods Authorization (RGA), if deemed necessary by the company. Please call 913-647-7300 and dial option 3 for the technical service dept. All returns must be shipped freight pre-paid to the company and with valid RGA before they will be processed.

Aeromotive will examine any product returned with the proper authorization to determine if the failure resulted from a defect or from abuse, improper installation, misapplication or alteration. Aeromotive will then, at it's sole discretion, return, repair or replace the product.

If any Aeromotive product is determined defective, buyer's exclusive remedy is limited in value to the sale price of the good. In no event shall Aeromotive be liable for incidental or consequential damages.

Aeromotive expressly retains the right to make changes and improvements in any product it manufactures and sells at any time. These changes and improvements may be made without notice at any time and without any obligation to change the catalogs or printed materials.

Aeromotive expressly retains the right to discontinue at any time and without notice any Aeromotive product that it manufactures or sells.

This warranty is limited and expressly limits any implied warranty to one year from the date of the original retail purchase on all Aeromotive products.

No person, party or corporate entity other than Aeromotive shall have the right to: determine whether or not this Limited Warranty is applicable to any Aeromotive product, authorize any action whatsoever under the terms and conditions of this Limited Warranty, assume any obligation or liability of any nature whatsoever on behalf of Aeromotive under the terms and conditions of this Limited Warranty.

This Limited Warranty covers only the product itself and not the cost of installation or removal.

This Limited Warranty is in lieu of and expressly excludes any and all other warranties, expressed or implied. This Limited Warranty gives you specific legal rights, and you may also have other rights which vary from state to state.