



AEROMOTIVE
Part # 14136
'04-'06 Subaru STI Fuel Rails
INSTALLATION INSTRUCTIONS

CAUTION:

Installation of this product requires detailed knowledge of automotive systems and repair procedures. We recommend that this installation be carried out by a qualified automotive technician.

Installation of this product requires handling of gasoline. Ensure you are working in a well ventilated area with an approved fire extinguisher nearby. Extinguish all open flames, prohibit smoking and eliminate all sources of ignition in the area of the vehicle before proceeding with the installation.

When installing this product, wear eye goggles and other safety apparel as needed to protect yourself from debris and sprayed gasoline.

WARNING!

The fuel system is under pressure. Do not open the fuel system until the pressure has been relieved. Refer to the appropriate vehicle service manual for the procedure and precautions for relieving the fuel system pressure.

Aeromotive system components are not legal for sale or use on emission controlled motor vehicles.

The enclosed Aeromotive fuel rails utilize o-ring sealed AN-08 style ports; these ports are **NOT PIPE THREAD** and utilize **NO THREAD SEALANT**. To use the enclosed fuel rails in your vehicle's fuel system you must install the necessary adapter fittings and o-rings, high pressure fuel lines and regulator to adapt your system to the configuration and ports of these fuel rails. Please call for a catalog of the complete line of quality Aeromotive products.

When installing o-rings it is important to place a small amount of light oil on both the o-ring and the mating surface to ease installation and prevent damaging the o-ring.

The following installation instructions are for a typical installation, for specific year and model installation instructions please refer to your vehicles service manual.

1. Once the engine has been allowed to cool, disconnect the negative battery cable, relieve fuel system pressure and drain engine coolant, referring to the appropriate vehicle service manual for the procedure on doing so.
2. First the factory manifold must be removed using the following steps, for specific details and instructions refer to the factory service manual.
3. Remove the turbo intercooler (top mount only) and air intake duct.
4. Disconnect all the wiring harness connections, noting where each goes.
5. Remove the bolts holding accessories and brackets to the manifold.
6. Disconnect all vacuum lines from the manifold, noting where each goes.
7. Remove the tumbler valve bolts connecting them to the heads, keeping the intake bolted to the top of the tumbler valve. In some cases it may be easier to remove the tumbler valves from the intake manifold.
8. Disconnect the fuel lines from the fuel rail assembly located on the driver side by the firewall, placing clean shop towels around the fuel lines to catch any gasoline that may be spilled during their removal
9. Carefully lift off the intake manifold, tumbler valve, OE fuel rail assembly.
10. Remove the three bolts holding the OE fuel lines to the bottom of the intake manifold.
11. Remove the four bolts holding the OE fuel rails to the tumbler valves.
12. Remove the OE fuel rail assembly from the intake manifold assembly, being careful not to damage the fuel injector pipe insulator between the bottom of the OE fuel rail and the tumbler valve.

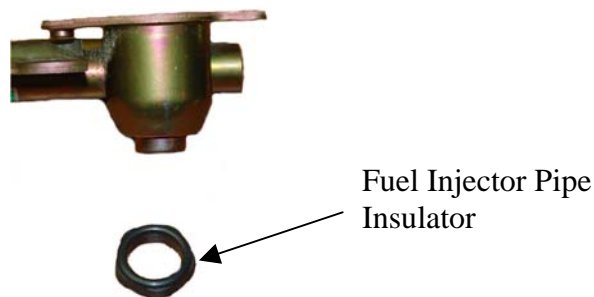

13. Remove each of the injector spring clips.

14. Place clean shop towels around the injectors to catch any gasoline that may be spilled during their removal. Remove each of the injectors from the manifold by gently pulling upward on each of the injectors.



15. Remove the old o-rings from the fuel injectors, inspect the injectors for any dirt or debris and clean if needed. It is suggested that the old o-rings be replaced, contact your local auto parts store for replacement o-rings.
16. Coat the new fuel injector o-rings with a light oil to ease installation.
17. Carefully install the new injector o-rings on the injectors.
18. The backside (the end closest to the vehicles firewall) of the Aeromotive fuel rail should have a port plug installed in it. Install the appropriate union fittings and o-rings in each end of the fuel rail, we recommend Aeromotive p/n 15605 for AN-06 or Aeromotive 15607 for AN-08. The front of the fuel rail on the right side (passenger) of the motor will be a close fit, we recommend using an AN-08 90-degree Male ORB hose end, Aeromotive p/n 15665.

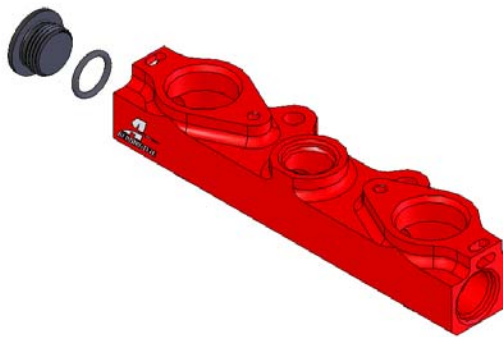

19. Place a thin coat of light oil in the fuel rail injector bores to help prevent cutting the o-rings during installation.
20. Carefully place each of the fuel injectors in the corresponding fuel injector bore of the Aeromotive fuel rails.

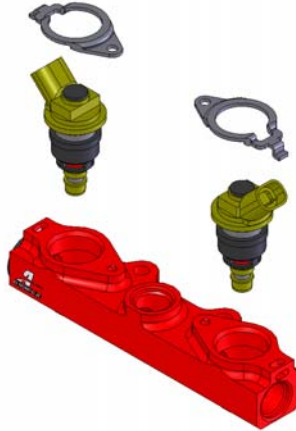

21. Reinstall the injector retaining clips and tighten screws.

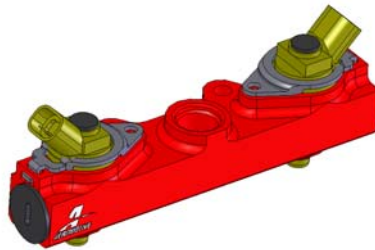

22. Inspect the fuel injector pipe insulators and replace if needed. Install each of the sealing washers on the bottoms of the fuel rail.

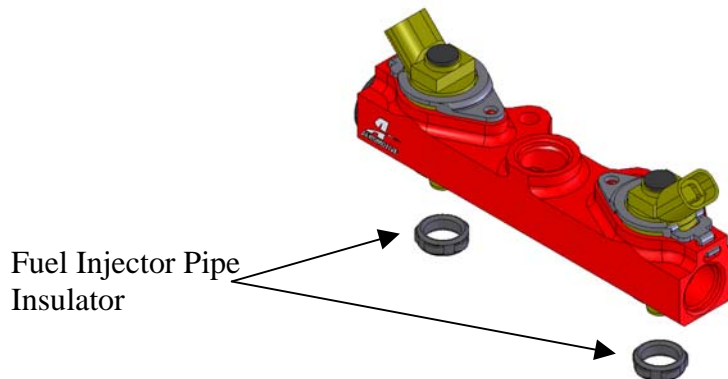

23. Place each of the Aeromotive fuel rail / injector assemblies onto each of the tumbler valves, being sure to align the bottom of the fuel rail with the injector bores in the tumbler valve.
24. Reinstall the fuel rail mounting bolts and tighten.
25. Reinstall intake manifold assembly replacing gaskets and retightening bolts as outlined in factory service manual.

Note: When reinstalling the tumbler valve / intake manifold assembly locate the sensor on the passenger side of the block directly behind the fuel rail and connect the wiring. With the bolts installed loosely in the tumbler valves make sure there is clearance between the plug in the back side of the fuel rail and the sensor by sliding the tumbler valve assembly forward then torque down the tumbler valves as outline in the service manual.

26. Using an after-market fuel pressure regulator, Aeromotive p/n 13101 or 13109 or similar, in conjunction with high pressure fuel lines and fittings, plumb the remainder of the fuel system.

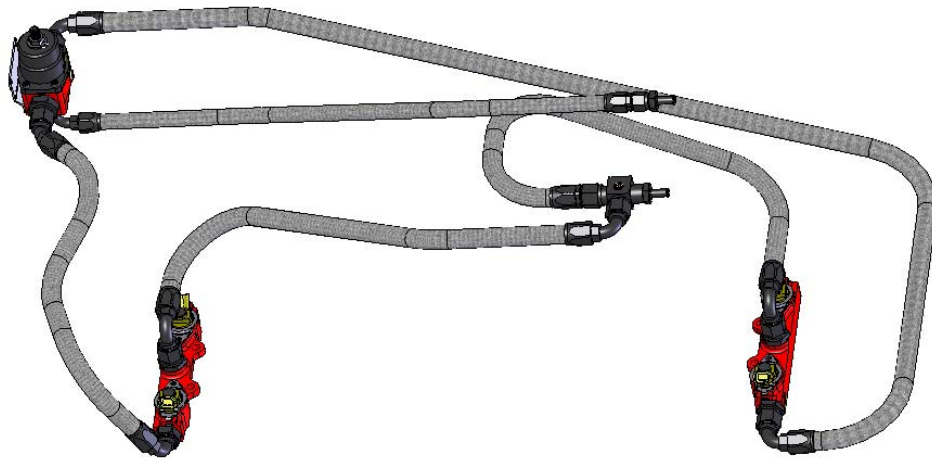

Ensure the any spilled gasoline and any gasoline soaked shop towels are cleaned up and removed from the vicinity of the vehicle!

27. Reinstall any electrical wiring, vacuum lines, fuel lines and throttle body components that where removed for the original fuel rail removal.
28. Refill engine coolant and check system for leaks

29. Reconnect the battery and turn the ignition to the ON position WITHOUT starting the car. After several second turn the ignition key to the OFF position, wait one minute. Repeat this process until you pressurize the fuel system.
30. With fuel pressure in the system, check for leaks from and around all the fuel system components and all fuel lines and connections. If any fuel leaks are found, turn the ignition key to the OFF position, remove any spilled gasoline and repair the leak before proceeding.
31. Once the fuel system has been confirmed to be leak free, test drive the vehicle to insure proper operation and re-check the fuel and coolant systems for leaks. If any leaks are found, immediately shutoff the engine and repair the leak(s).

Thanks for purchasing another quality product designed, engineered and manufactured in
Kansas City, USA!

AEROMOTIVE, INC.
7805 Barton Street, Lenexa, KS 66214
913-647-7300 fax 913-647-7207
www.aeromotiveinc.com

AEROMOTIVE, INC. LIMITED WARRANTY

This Aeromotive Product, with proof of purchase dated on or after January 1, 2003, is warranted to be free from defects in materials and workmanship for a period of one year from the original date of purchase. No warranty claim will be valid without authentic, dated proof of purchase.

This warranty is to the original retail purchaser and none other and is available directly from Aeromotive and not through any point of distribution or purchase.

If a defect is suspected, the retail purchaser must contact Aeromotive directly to discuss the problem, possible solutions and obtain a Return Goods Authorization (RGA), if deemed necessary by the company. Please call 913-647-7300 and dial option 3 for the technical service dept. All returns must be shipped freight pre-paid to the company and with valid RGA before they will be processed.

Aeromotive will examine any product returned with the proper authorization to determine if the failure resulted from a defect or from abuse, improper installation, misapplication or alteration. Aeromotive will then, at it's sole discretion, return, repair or replace the product.

If any Aeromotive product is determined defective, buyer's exclusive remedy is limited in value to the sale price of the good. In no event shall Aeromotive be liable for incidental or consequential damages.

Aeromotive expressly retains the right to make changes and improvements in any product it manufactures and sells at any time. These changes and improvements may be made without notice at any time and without any obligation to change the catalogs or printed materials.

Aeromotive expressly retains the right to discontinue at any time and without notice any Aeromotive product that it manufactures or sells.

This warranty is limited and expressly limits any implied warranty to one year from the date of the original retail purchase on all Aeromotive products.

No person, party or corporate entity other than Aeromotive shall have the right to: determine whether or not this Limited Warranty is applicable to any Aeromotive product, authorize any action whatsoever under the terms and conditions of this Limited Warranty, assume any obligation or liability of any nature whatsoever on behalf of Aeromotive under the terms and conditions of this Limited Warranty.

This Limited Warranty covers only the product itself and not the cost of installation or removal.

This Limited Warranty is in lieu of and expressly excludes any and all other warranties, expressed or implied. This Limited Warranty gives you specific legal rights, and you may also have other rights which vary from state to state.