



**18660, 18661, 18662 & 18663 Stealth Fuel Cell
INSTALLATION INSTRUCTIONS**

WARNING!

The fuel system is under pressure. Do not open the fuel system until the pressure has been relieved. Refer to the appropriate vehicle service manual for the procedure and precautions for relieving the fuel system pressure.

To use this stealth fuel cell in your vehicle's fuel system, **you must do the following:**

- **A by-pass style fuel pressure regulator must be used in the system.**
- **Utilize high pressure fuel lines, fittings and o-rings for all connections from the fuel tank to the fuel pressure regulator.**
- **For long term driving applications where continuous run times exceed 30 minutes and fuel capacity is less than 10 gallons, Aeromotive recommends the installation of a pump voltage control module, Aeromotive p/n 16306.**

Failure to follow the above may result in fuel leakage, bursting of the fuel lines, poor vehicle performance and/or decreased fuel pump life! Improper installation will void all warranties for this product!

Aeromotive system components are not legal for sale or use on emission controlled motor vehicles

CAUTION:

Installation of this product requires detailed knowledge of automotive systems and repair procedures. We recommend that this installation be carried out by a qualified automotive technician.

Installation of this product requires handling of gasoline. Gasoline vapors are highly flammable. Ensure you are working in a well ventilated area with an approved fire extinguisher nearby. Extinguish all open flames, prohibit smoking and eliminate all sources of ignition in the area of the vehicle before proceeding with the installation.

The enclosed Aeromotive fuel pump utilizes a AN-10 ORB (O-ring Boss Ports) style outlet port; these ports are **NOT PIPE THREAD** and utilize **NO THREAD SEALANT**.

Compatible Fuels:

Pump Gas
Race Gas
E85
Diesel

The following steps are typical of most installations:

1. Find a good mounting location on your vehicle for the Aeromotive Stealth Fuel Cell. Remove any sharp edges from the area around the fuel cell prior to mounting. Mount the cell in accordance to the requirements set forth by your racing sanctioning body. Fuel cells should always have good solid floor support under the cell for the weight of the fuel. The top, bottom and sides of the cell must have the proper support. To make securing the Aeromotive Stealth Cell easier strap kits are available from most major fuel cell manufactures.

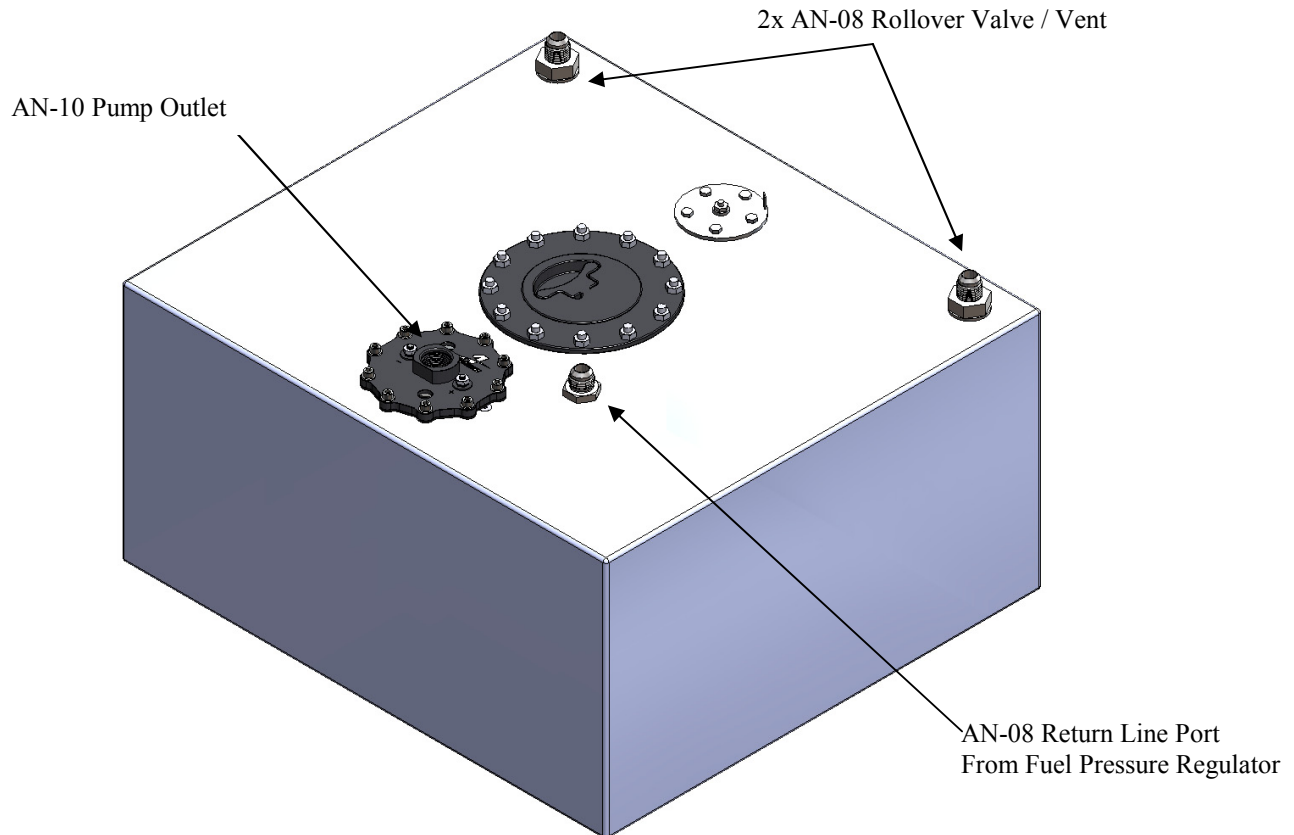

2. Connect AN-08 lines to the tank vent fittings. Tank vent lines must be ran outside the vehicle.
3. Connect the fuel pump outlet to a fuel filter (Aeromotive p/n 12301 (10 micron) or 12335 (40 micron)).
Make sure you use high pressure (150 psi minimum) fuel line for this connection!
For AN-10 Line, Aeromotive p/n 15608, (AN-10 ORB to AN-10 Flare Union)
For AN-08 Line, Aeromotive p/n 15610, (AN-10 ORB to AN-08 Flare Union)
For AN-06 Line, Aeromotive p/n 15609, (AN-10 ORB to AN-06 Flare Union)

4. If you are running an EFI System, connect the fuel filter outlet to the fuel rail(s) and then to a bypass style fuel pressure regulator (Aeromotive p/n 13101 / 13109 or similar). **Make sure you use high pressure (150 psi minimum) fuel line for this connection!** For optimum fuel system performance in EFI applications, Aeromotive recommends a balanced system with the fuel pressure regulator as the last component in the system as shown in the following diagram.

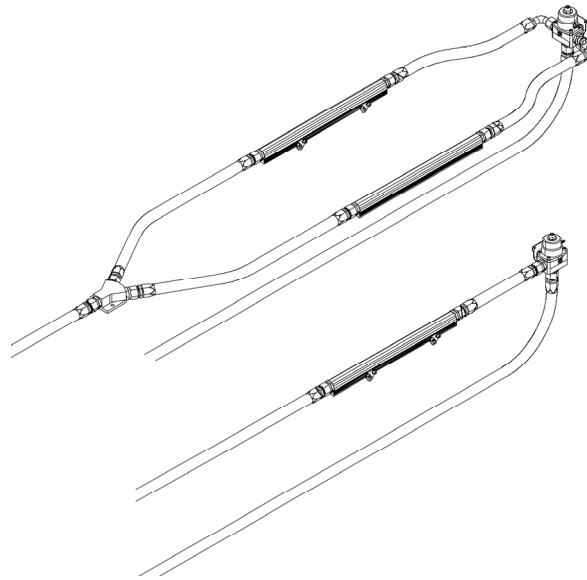

5. If you are running a Carbureted System, connect the fuel filter outlet to a Bypass style fuel pressure regulator (Aeromotive p/n 13204 or similar).

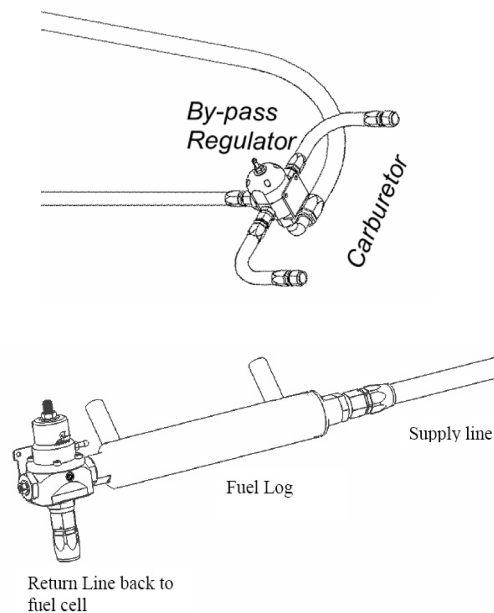

Note: Be sure to route all electrical wires clear of any moving suspension or drivetrain components and any exhaust components! Protect wires from abrasion and road obstructions or debris.

6. Connect the return port on the fuel pressure regulator to the AN-08 Port on the Aeromotive Stealth Fuel Cell.
7. Connect the Aeromotive fuel pump using stranded, insulated copper wire, in the sizes shown, with matching crimp-type connectors for all connections. A wiring kit is available from Aeromotive, p/n 16301

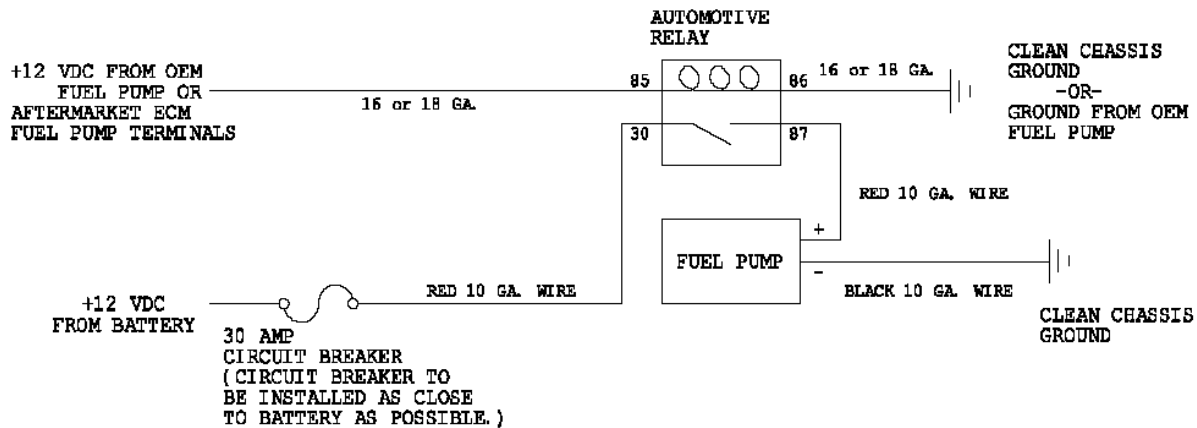

8. Connect the fuel sending unit output wire to a 0-90 ohm compatible fuel level gauge. 0 ohms reads empty, and 90 ohms reads full.
9. Attach a suitable fuel pressure gauge to the fuel system schrader valve, fuel rail or fuel pressure regulator.
P/N 15632 0-15 PSI (1 1/2") "Dry" Fuel Pressure Gauge
P/N 15633 0-100 PSI (1 1/2") "Dry" Fuel Pressure Gauge

Ensure that any spilled fuel and any fuel soaked shop towels are cleaned up and removed from the vicinity of the vehicle.

CAUTION: While performing the following steps, if any fuel leaks are detected, immediately turn the ignition to OFF, remove any spilled fuel and repair the leak(s) before proceeding!

10. Turn the ignition to ON **without starting the engine**, allow the pump to run for several seconds and check the fuel pressure. If there is no pressure, turn the ignition to OFF, wait one minute, then turn the ignition to ON and recheck the pressure. Repeat this ignition OFF and ON procedure until the gauge registers pressure or you detect a fuel leak. If no pressure is registered on the gauge after running the pump for several seconds and you have found no leaks, check all fuel and electrical connections to determine the cause.
11. Once the fuel pressure gauge registers pressure, start the engine. If you have installed an adjustable fuel pressure regulator, adjust it to the desired setting.
12. Shut the engine off. Using suitable clips and other mounting hardware, secure the newly installed fuel lines and electrical wires by attaching them to the vehicle chassis.
13. Test-drive the vehicle to insure proper operation and re-check the fuel system for leaks. **If any leaks are found, immediately discontinue use of the vehicle and repair the leak(s)!**

Thanks for purchasing another quality product designed, engineered and manufactured in Kansas City, USA!

AEROMOTIVE, INC.
 7805 Barton St, Lenexa, KS 66214
 913.647.7300 fax 913.647.7207

AEROMOTIVE, INC. LIMITED WARRANTY

This Aeromotive Product, with proof of purchase dated on or after January 1, 2003, is warranted to be free from defects in materials and workmanship for a period of one year from the original date of purchase. No warranty claim will be valid without authentic, dated proof of purchase.

This warranty is to the original retail purchaser and none other and is available directly from Aeromotive and not through any point of distribution or purchase.

If a defect is suspected, the retail purchaser must contact Aeromotive directly to discuss the problem, possible solutions and obtain a Return Goods Authorization (RGA), if deemed necessary by the company. Please call 913-647-7300 and dial option 3 for the technical service dept. All returns must be shipped freight pre-paid to the company and with valid RGA before they will be processed.

Aeromotive will examine any product returned with the proper authorization to determine if the failure resulted from a defect or from abuse, improper installation, misapplication or alteration. Aeromotive will then, at it's sole discretion, return, repair or replace the product.

If any Aeromotive product is determined defective, buyer's exclusive remedy is limited in value to the sale price of the good. In no event shall Aeromotive be liable for incidental or consequential damages.

Aeromotive expressly retains the right to make changes and improvements in any product it manufactures and sells at any time. These changes and improvements may be made without notice at any time and without any obligation to change the catalogs or printed materials.

Aeromotive expressly retains the right to discontinue at any time and without notice any Aeromotive product that it manufactures or sells.

This warranty is limited and expressly limits any implied warranty to one year from the date of the original retail purchase on all Aeromotive products.

No person, party or corporate entity other than Aeromotive shall have the right to: determine whether or not this Limited Warranty is applicable to any Aeromotive product, authorize any action whatsoever under the terms and conditions of this Limited Warranty, assume any obligation or liability of any nature whatsoever on behalf of Aeromotive under the terms and conditions of this Limited Warranty.

This Limited Warranty covers only the product itself and not the cost of installation or removal.

This Limited Warranty is in lieu of and expressly excludes any and all other warranties, expressed or implied. This Limited Warranty gives you specific legal rights, and you may also have other rights which vary from state to state.